

# Mounting instructions for walls made of lightweight materials (drywall or similar)

## 01 Wall Shelf

weld & co

### PLEASE NOTE:

The wall anchors and screws needed for mounting are NOT included. Please use the correct types of screws and wall anchors for the material of your wall and, if necessary, ask at the hardware store for the appropriate fastening materials.

### MOUNTING:

1. Using a spirit level and a pencil, draw an approx. 80 cm line on the wall where you plan to hang the shelf.
2. Mark the middle of the line with a pencil. From this point, measure 35 cm to the left and to the right, marking these spots. The two marks indicate the distance between the two shelf supports, 70 cm.
3. Center the shelf supports on the left and right marks and use the pencil to trace the screw-holes onto the wall.
4. Screw a wall anchor into the center of each of the four marks. For precise results, we recommend pre-drilling a small hole for each anchor.
5. Screw each shelf support securely into the anchors with two screws.
6. Place the shelf onto the shelf supports.

### OUR TIP:

Get a second person to help you hang the shelf.

### PLEASE NOTE:

The full load-bearing capacity of the shelf can only be met if it is securely and correctly attached to the wall.

### TECHNICAL SUPPORT:

post@weldco.de

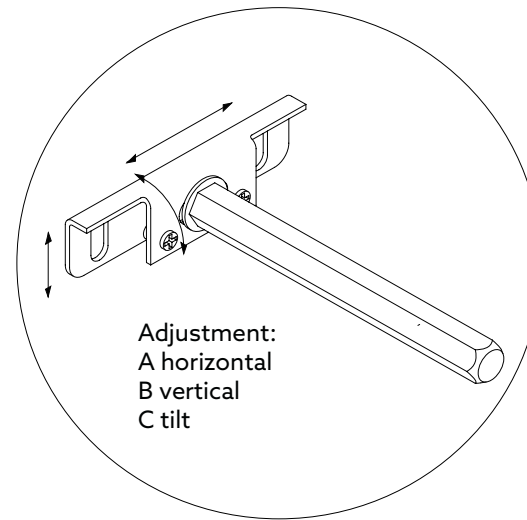

### YOU'LL NEED:

- Spirit level
- Pencil
- Drill
- Drill bit
- Phillips screwdriver

